

PRELIMINARY
CONFIDENTIAL

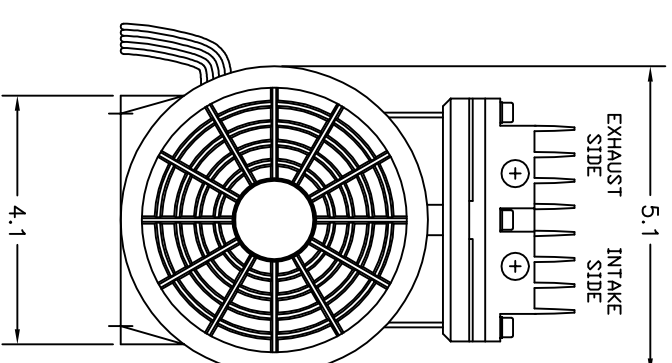
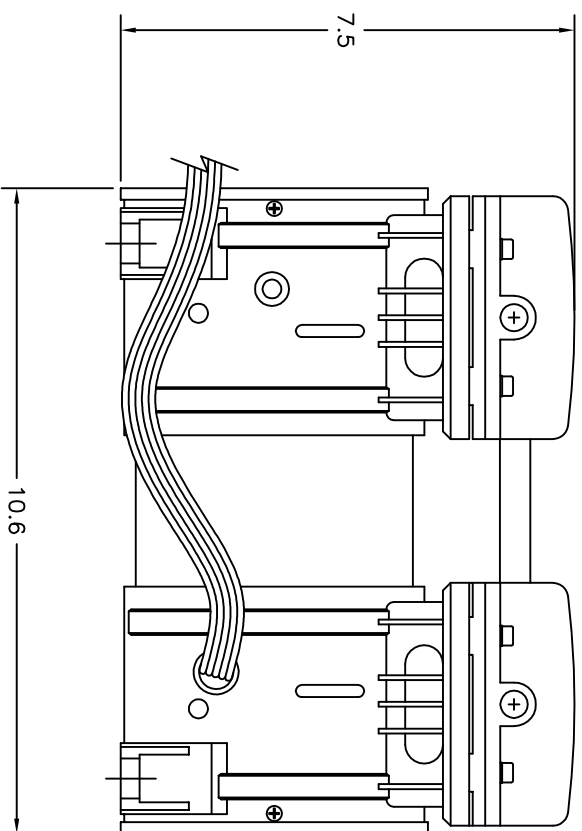
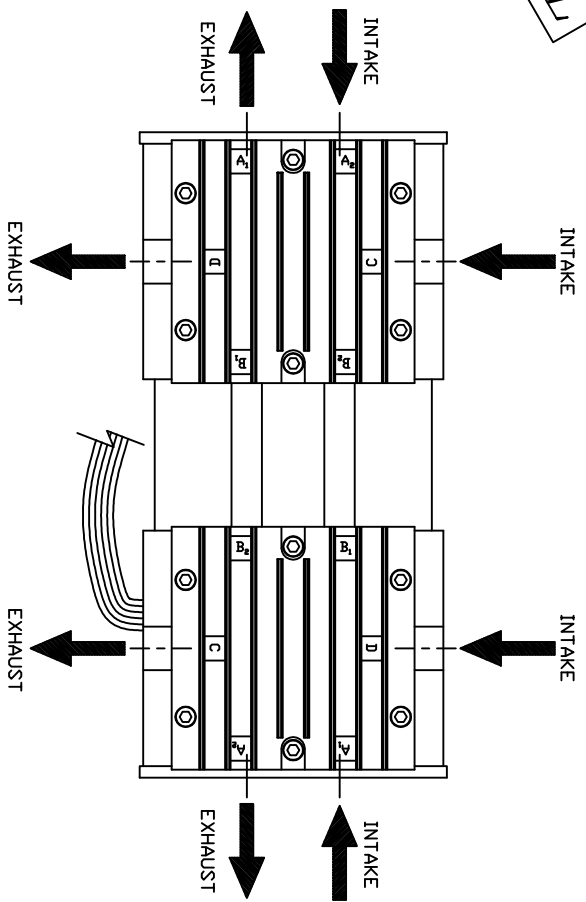

ITEM	STANDARD
RATED VOLTAGE (VAC)	110V/60Hz
INPUT POWER (W)	≤530W
INPUT CURRENT (A)	5.2A
RATED FLOW (m³/h)	≥3.6m³/h@400kPa
RATED WORKING PRESSURE (kPa)	400kPa
MAX. INSTANTANEOUS PRESSURE (kPa)	≥800kPa
RATED SPEED (RPM)	≥1650 RPM
SOUND dB (A)	566 dB(A)
AMBIENT TEMPERATURE (°C)	5-40 °C
INSULATION LEVEL	B
COOL INSULATION RESISTANCE (NORMAL) MΩ	≥100MΩ
DIELECTRIC STRENGTH	1800V/50Hz 1 SECOND
THERMAL PROTECTOR	135±5°C
CAPACITOR (μF)	50μF ±5
NET WEIGHT (KG)	9KG
INSTALLATION SIZE (mm)	223.2mm x 89mm (4-M6)
EXTERIOR SIZE (mm)	268.8mm x 128mm x 189.7mm
RESTART PRESSURE (kPa)	0kPa

ISS #	ECD #	REV	DESCRIPTION	DATE	APPROV
		-1	PRELIMINARY		

REVISIONS

- NOTES:
1. ALL INTAKE AND EXHAUST PORTS ARE 1/4NPT
 - 2.

PROPRIETARY CONFIDENTIAL

APPROVALS		DATE
DESIGNER		
DRAWN BY		
CHECKED BY		
OTHER		

NOTICE OF PROPRIETARY AND CONFIDENTIAL PROPERTY
THESE DRAWINGS AND SPECIFICATIONS ARE THE PROPERTY OF PROTEL, INC. AND SHALL NOT BE REPRODUCED, COPIED OR USED AS THE BASIS FOR MANUFACTURE OR SALE OF ANY APPARATUS WITHOUT THE EXPRESS WRITTEN AUTHORIZATION FROM PROTEL, INC.

UNLESS OTHERWISE SPECIFIED ALL DIMENSIONS ARE IN INCHES (MM) FRACTIONS XX + DECIMALS + ANGLES .XXX +

MATERIAL FINISH

SEE SEPARATE PARTS LIST
P/N: HDS0000673

Protel
Innovation is our business

COMPRESSOR 550W TWIN CYL

PRODUCT NUMBER	DRAWING NUMBER	DWG REV
HDS0000673	240376	-1

SCALE 1:2 CAD NUMBER 240376-1 SHEET 1 OF 2

PRELIMINARY
CONFIDENTIAL